



# OWNER'S MANUAL

United States and Canada

**2-in-1 Oven  
Warmer and Pizza Oven (110V)**  
BBQ10967E



© 2010 LMS, Inc.

Cal Spas Home Resort™

[www.calflamebbq.com](http://www.calflamebbq.com)

<b>Safety Instructions .....</b>	<b>1</b>
<b>Set-up .....</b>	<b>3</b>
<b>Using Your Pizza Oven.....</b>	<b>5</b>
<b>Care and Maintenance .....</b>	<b>7</b>
<b>Limited Warranty .....</b>	<b>8</b>

**This appliance is for household use only.**

Use the pizza oven only for its intended purpose as described in this guide.

Read and follow all instructions before using this appliance to prevent the potential risk of fire, electric shock, personal injury or damage to the appliance as a result of improper usage of the appliance. Improper installation, adjustment, alteration, service or maintenance can cause injury or property damage.

**Electrical Specifications:**

- 115 volts
- 12.0 amps
- 1265 watts

Copyright 2010 Lloyds Equipment, Inc. All rights reserved. Duplication without written consent is strictly prohibited.

Cal Flame ® is a registered trademark.

Due to continuous improvement programs, all models, operation, and/or specifications are subject to change without prior notice.

LTR50001052, Rev. B  
4/9/10

<p><b>CONTACT INFORMATION</b></p> <p>For customer service, please contact your authorized dealer immediately. If you need additional information and/or assistance, please contact:</p> <p>Customer Service Department 1462 East Ninth Street Pomona, CA 91766</p> <p>Toll Free: 1-800-CAL-SPAS Fax: 1-909-629-3890</p> <p><b><a href="http://www.calflamebbq.com">www.calflamebbq.com</a></b></p>
--

# Safety Instructions

## In Case of Smoke or Fire

**This is an electrical appliance --  
do not spray water into the oven!**

- Turn off the power **IMMEDIATELY**.
- Use a pizza peel to remove any smoking, burning, or charred food.  
**Do not reach your hands into the oven!**
- Place the food someplace safe, such as on top of the barbeque island, and if it is burning, extinguish it.
- Leave the door to the pizza oven open to let it ventilate.

## Placement and Location

**The Cal Flame electric pizza oven is designed for outdoor use only.**

- Never locate this appliance in an enclosed area, under a sealed overhead structure, or in any type of enclosed area such as a garage, shed, or breezeway. Keep clear of trees and shrubs.
- The electric pizza oven is not intended for installation in or on recreational vehicles or boats.
- Do not use the pizza oven as a storage area.

## Operation

- Do not use pizza oven for other than intended use.
- Never use the pizza oven if the hearth bricks are not properly installed.
- Never line the pizza oven with aluminum foil.
- Do not use fuel such as charcoal briquettes in an electric oven.
- Never leave the pizza oven unattended when in use.
- When using the pizza oven, do not touch the rack, hearth bricks, heating element, or immediate surroundings as these areas become extremely hot and can cause burns.

- Do not heat any unopened glass or metal container of food in the oven. Pressure may build up and cause the container to burst, possibly resulting in serious personal injury or damage to the oven.
- Do not operate the oven with a damaged heating element.
- Turn off controls when cooking is completed.
- Do not allow the hearth bricks to become encrusted with food runoff. Clean frequently.
- Do not completely cover the cooking rack. Leave air space to allow proper ventilation for even baking.

## **Precautions Regarding Children**

- Never leave children unattended in the area where the oven is being used. Close supervision of children is necessary when any appliance is use near children.
- Children must be taught that the appliance and utensils in or on it can be hot. Let hot utensils cool in a safe place, out of reach of small children. Children should be taught that an appliance is not a toy. Children should not be allowed to play with controls or other parts of the unit.

## Set-up

If your electric pizza oven is already installed in a Cal Flame barbecue island, it is nearly ready to use.

Open the oven door and remove all materials and packaging.

Remove the hearth bricks from their packaging and place them in the oven lengthwise from front to back.

Place the stainless steel rack on the hearth bricks.



When everything has been set in place, close the door turn the temperature control on the right. If the light does not turn on, check the plug inside the barbecue island to make sure the oven is plugged into a dedicated 110V grounded outlet. We strongly recommend having a contractor install a dedicated electrical service for your barbecue island. Do not use an extension cord.

### Cut-Out Dimensions

If you purchased your electric pizza oven with the intention of installing it in a barbecue island, use the diagram below to help you with placement and dimensions.

You need to have a dedicated 110V grounded electrical outlet to plug the pizza oven into. We strongly recommend having a contractor install a dedicated electrical service for your barbecue island. Do not use an extension cord.

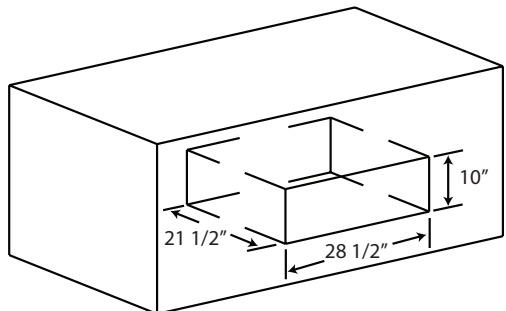

## Oven Dimensions

The actual usable space inside the oven are shown below.

Height is measured from the bottom of the heating element. Width is measured from the left wall to the right wall. Depth is measured from the back wall to the front of the hearth bricks.

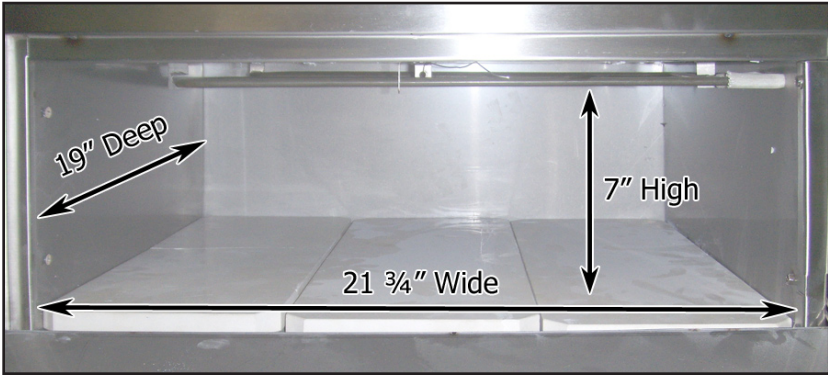

## Using Your Pizza Oven

**Read all instructions before you operate your pizza oven.**

This appliance has been tested for safe performance using conventional cookware. Do not use any devices or accessories that are not specifically recommended in this manual. The use of devices or accessories that are not expressly recommended in this manual can create serious safety hazards, results in performance problems, and reduce the life of the components of this appliance.

Clean only parts listed in this guide and use procedures recommended.



### **Caution! Burn Hazard!**

The heating element is located at the top of the oven and is not shielded. You need to exercise caution when placing food in the oven and removing it.

We recommend you use a pizza peel (a tapered wooden paddle) to get your food in and out of the oven.

Note: Pizza peel is NOT provided with oven.



Never touch the heating element. The heating element may be hot even though it is dark in color. Areas near the element may become hot enough to cause burns.

If you do not use a pizza peel, we strongly recommend using oven mitts, and not pot holders, to remove your food from the oven.

Do not attempt remove the heating element. It is not removable.

## Oven Operation

In addition to pizza, the 110V oven is suitable for cooking, baking, warming, or re-heating a variety of foods, such as pretzels, biscuits, cookies, bagels, sandwiches, french fries, or onion rings.

Turn the dial on the right side of the oven to the desired temperature. The power light will turn on when the oven is in use.

Oven temperatures shown on the dial are approximate. The actual temperature in your oven can vary depending on local weather conditions (extreme heat or cold) or the nature of your barbecue island.

Because the oven does not have a built-in thermometer, we recommend you place an oven thermometer under the rack to better determine the actual temperature of the oven.

When the oven has heated, avoid opening the door frequently. You lose valuable heat, which requires more time to re-heat the oven and cook your food.

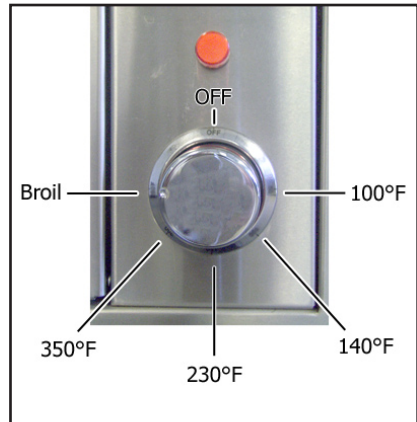

Place food on the food rack, not on the hearth bricks.

**There is a 4" high cooking area between the food rack and the heating element. Always ensure food does not come in contact with the heating element located at the top of the oven.**

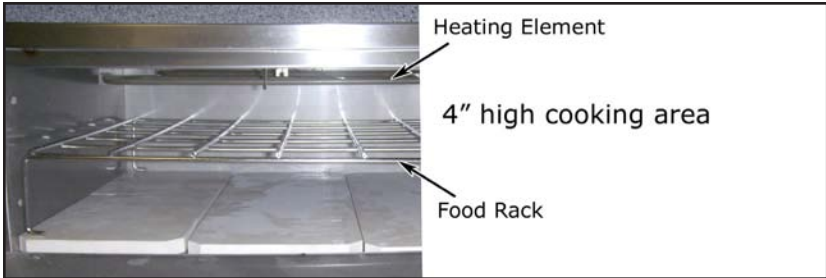

Food items that requires significant rising when baking, such as bread, high rising cakes, etc., should not be baked in the oven.

Never leave oven unattended during operation. Turn off oven when finished.

You can adjust the temperature with the vent slides located inside the door as shown below

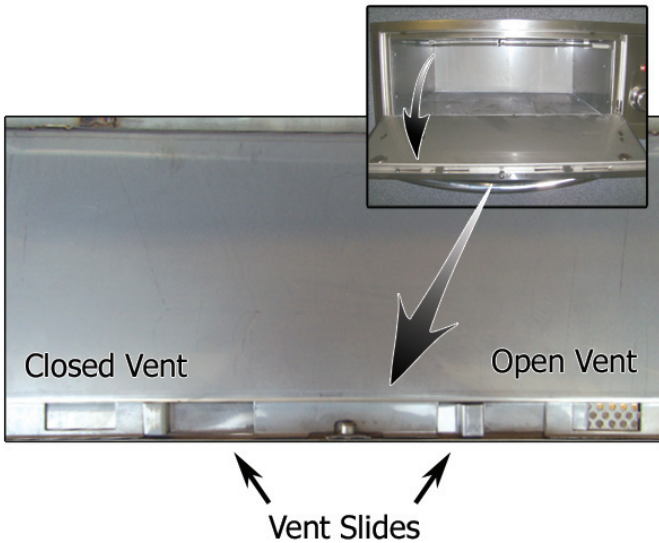

## Using Your Electric Grill

# Care and Maintenance

To assure safe and proper maintenance, we recommend you follow these directions carefully.

Clean internal parts of the oven regularly as determined by the amount of use and foods cooked. The entire oven should be cleaned at least once a year.

## Heating Element

Do not remove the heating element. Any food that may collect on it will burn off.

## Hearth Bricks and Rack

Wash the rack with detergent in hot water in the sink or in the dishwasher. Do not immerse a hot rack in water. Be sure to remove all food residue before cooking on the rack again.

## Care of Stainless Steel

Do NOT use wire wool pads, scrappers, harsh abrasive, scoring materials, bleaches, or harsh cleaners. This will cause scratching, scoring, rusting and pitting.

We recommend that you clean stainless steel components with a cleaner that is approved for stainless steel and only clean when the oven is cool and in indirect light. Never use steel wool.

## Control Area

Use mild cleaners, such as soapy water or mild liquid sprays. Wipe with sponge, damp cloth or paper towel. Do not scrub with steel wool pads or abrasive cleaners.

## Repair

Unless specifically recommended in this manual, do not repair or replace any part of the oven except as specifically recommended in this manual. A qualified technician should perform all service. Any repairs made by a non-L.M.S. approved dealer technician will void your warranty.

## Limited Warranty

Lloyds Material Supply (LMS) warrants the 110V electric pizza oven from defects in material and workmanship for a period of one year from the original date of purchase.

### Extent of Warranty

This warranty is only valid on Cal Flame 110V electric pizza oven delivered in the United States or Canada and extends through the selling dealer to the original purchaser at the original site of installation. This warranty becomes valid at time of purchase and ends either by specified time-frame listed above or upon owner transfer or relocation.

### Warranty Performance

All Cal Flame 110V electric pizza ovens are manufactured with the highest quality appliances and are warranted to be free from defects in material and workmanship at time of delivery. In the event of a malfunction or defect covered under the terms of this warranty, a factory authorized service agent of LMS will perform the necessary repairs. To obtain service, contact the selling dealer. In the event the consumer is unable to obtain satisfactory customer service from the selling dealer or service agent, written notification must be given to the LMS Customer Relations Department within 30 days of the reported failure. There will be no charge for parts on a covered item within the one year warranty period. However, the service agent may assess a reasonable travel or mileage charge per service call. If LMS determines that repair of a covered item is not feasible, LMS reserves the right to replace the defective merchandise with merchandise equal in value to the original purchase price. Warranty repair and / or replacement is the sole discretion of LMS and this warranty does not cover costs therein, including but not limited to: freight, removal, re-installation, etc. This warrant is non-transferable and may not be extended beyond the above mentioned time frames under any circumstances, by any of LMS's representatives.

### Warranty Limitations

This warranty is void if the 110V electric pizza oven has been subject to negligence, alteration, misuse, repairs, dings, dents, scratches, or incorrect and / or prohibited applications, as specified in the owner's

manual. Service by non-LMS authorized representatives, acts of God and other cases beyond the control of LMS are not covered by this warranty. Please refer to the owner's manual for examples of exclusions and common acts invalidating this warranty. This limited warranty applies only to the 110V electric pizza oven used for personal, family, and outdoor household purposes. This warranty does not apply to labor charges on grills, replacement parts and hardware.

Examples of common acts invalidating this warranty include but are not limited to:

- Scratches caused by normal use.
- Damage caused by extreme weather conditions (hot, cold, etc.)
- Damage caused by dirt, sand, and/or water damage.
- Damage caused by continued operation of the barbecue with either known or unknown problems.
- Damage caused by direct sunlight.
- Damage caused as a result of failure to follow the operating instructions as defined in this owner's manual.

This limited warranty applies only to barbecues normally used for personal, family, or household purposes and specifically excludes commercial use.

## **Disclaimers**

LMS shall not be liable for loss of use of the pizza oven or other incidental or consequential costs, expense or damages, which may include, but are not limited to, removal of permanent deck or other custom fixtures or the necessity for crane removal. Any implied warranty shall have duration equal of the applicable warranty stated above.

## **Legal Remedies**

This limited warranty gives you specific legal rights. You may have other rights, which may vary from state to state.

See your Cal Flame barbecue dealer for a copy of the applicable warranty, details and any questions you may have regarding the warranty coverage on your electric grill.



LMS Customer Service Department  
1462 East Ninth Street  
Pomona, CA 91766

Toll Free: 1-800-CAL-SPAS  
Fax: 1-909-629-3890

**[www.calflamebbq.com](http://www.calflamebbq.com)**