



United States, Canada, and International

PORTABLE SPA PRE-DELIVERY GUIDE



www.calspas.com

Contents

Pre-Delivery Checklist	1
Planning the Best Location.....	1
Site Preparation	3
Getting the Spa Into Your Yard.....	4
Electrical Requirements	6
<i>Electrical Requirements – US and Canada.....</i>	<i>6</i>
<i>240 Volt Electrical Installation</i>	<i>6</i>
<i>120 Volt Electrical Installation</i>	<i>10</i>
<i>Electrical Installation -- Europe</i>	<i>11</i>
<i>230 Volt Electrical Installation</i>	<i>11</i>
Spa Technical Specifications	14

This guide is intended for owners of Cal Spas portable spas.

If you have an in-ground spa, you will need the Cal Spas In-ground Spa Pre-Delivery Guide, available on the Cal Spas web site.

Copyright 2009 LMS, Inc. All rights reserved. Duplication without written consent is strictly prohibited.

Cal Spas® is a registered trademark.

Due to continuous improvement programs, all models, operation, and/or specifications are subject to change without prior notice.

LTR20091024, Rev. D
6/19/09

CONTACT INFORMATION

For customer service, please contact your authorized dealer immediately. If you need additional information and/or assistance, please contact:

LMS Customer Service Department
1462 East Ninth Street
Pomona, CA 91766

Toll Free: 1-800-CAL-SPAS
Fax: 1-909-629-3890

www.calspas.com

Pre-Delivery Checklist

Most cities and counties require permits for exterior construction and electrical circuits. In addition, some communities have codes requiring residential barriers such as fencing and/or self-closing gates on property to prevent unsupervised access to the property by children under the age of 5. Your dealer can provide information on which permits may be required and how to obtain them prior to the delivery of your spa.

For additional operating and installation information, please see your selling dealer.

Before Delivery	
	Plan your delivery route
	Choose a suitable location for the spa
	Lay a 3" - 4" concrete slab
	Install dedicated electrical supply
After Delivery	
	Place spa on slab
	Connect electrical components

Planning the Best Location

Safety first

Do not place your spa within 10 feet (3 m) of overhead power lines.

Make sure the spa is positioned so that access to the equipment compartment and all side panels will not be blocked. Be certain that your installation will meet all city and local safety codes and requirements.

Consider how you will use your spa

How you intend to use your spa will help you determine where you should position it. For example, will you use your spa for recreational or therapeutic purposes? If your spa is mainly used for family recreation, be sure to leave plenty of room around it for activity. If you will use it for relaxation and therapy, you'll probably want to create a specific mood around it.

Plan for your environment

If you live in a region where it snows in the winter or rains frequently, place the spa near a house entry. By doing this, you will have a place to change clothes and not be uncomfortable.

Consider your privacy

In a cold-weather climate, bare trees won't provide much privacy. Think of your spa's surroundings during all seasons to determine your best privacy options. Consider the view of your neighbors as well when you plan the location of your spa.

Provide a view with your spa

Think about the direction you will be facing when sitting in your spa. Do you have a special landscaped area in your yard that you find enjoyable? Perhaps there is an area that catches a soothing breeze during the day or a lovely sunset in the evening.

Keep your spa clean

Prevent dirt and contaminants from being tracked into your spa by placing a foot mat at the spa's entrance where the bather's can clean their feet before entering your spa. You may also consider keeping a small water-filled basin nearby for bathers to rinse their feet before entering your spa.

In planning your spa's location, consider a location where the path to and from the house can be kept clean and free of debris.

Allow for service access

Many people choose to install a decorative structure around their spa. If you are installing your spa with any type of structure on the outside, such as a gazebo, remember to allow access for service. It is always best to design special installations so that the spa can still be accessed.

Site Preparation

Your spa needs a solid and level foundation. The area that it sits on must be able to support the weight of the spa, with water and the occupants who use it. If the foundation is inadequate, it may shift or settle after the spa is in place, causing stress that could DAMAGE YOUR SPA SHELL AND FINISH.

Damage caused by inadequate or improper foundation support is not covered by the warranty. It is the responsibility of the spa owner to provide a proper foundation for the spa.

Place the spa on an elevated 3" - 4" concrete slab. Pavers, gravel, brick, sand, timbers or dirt foundations are **not** adequate to support the spa.

We strongly recommended that a qualified, licensed contractor prepare the foundation for your spa.

If you are installing the spa indoors, pay close attention to the flooring beneath it. Choose flooring that will not be damaged or stained.

If you are installing your spa on an elevated wood deck or other structure, it is highly recommended that you consult a structural engineer or contractor to ensure the structure will support the weight of 150 pounds per square foot.

To properly identify the weight of your new spa when full, remember water weighs 8.33 lbs. per gallon. For example, an average 8' spa holds approximately 500 gallons of water. Using this formula, you will find that the weight of the water alone is 4,165 lbs. Combined with the dry weight of the spa you will note that this spa will weigh approximately 5,000 lbs. when full of water.

Your Cal Spas retailer can help you with your foundation and more. Your retailer has a wealth of information and experience about how to get the most out of your spa and can provide you with a full line of accessories that are designed to complement your spa and increase your enjoyment.

Getting the Spa Into Your Yard

Check the Dimensions of Your New Spa

The specification chart on page 14 lists your spa's model and its dimension as it sits on the delivery cart. During delivery, the spa must remain on the delivery cart at all times. Compare the dimensions to the width of the gates, sidewalks, and doorways along the delivery route. It may be necessary for you to remove a gate or partially remove a fence in order to provide an unobstructed passageway to the installation location.

Plan the Delivery Route

Consider the following when planning your delivery route:

- Check the width of gates, doors and sidewalks to make sure your spa will pass through unobstructed. You may have to remove a gate or part of a fence to allow for adequate width clearance.
- Are there low roof eaves, overhanging branches or rain gutters that could be an obstruction to overhead clearance?
- 8' spas need at least 42" wide gate and 9' height clearance.
- If the delivery route will require a 90° turn, check the measurements at the turn to ensure the spa will fit.
- Are there protruding gas meters, water meters or A/C units on your home which will cause obstructions along the delivery path to your yard?
- Are there stairs in your delivery route? If so, you must consult your Cal Spas dealer prior to delivery to make adequate preparations.

Special Circumstances

The use of a crane for delivery and installation may become necessary if you are unable to provide an adequate delivery route. It is used primarily to avoid injury to your spa, your property or to delivery personnel. Your Cal Spas dealer may be able to assist you with the arrangements. If your spa delivery requires the use of a crane, the cost of a crane is generally not included in the standard delivery service.

Check your width clearance

- Check all gates
- Protruding electric meters
- Gas meters
- A/C units

Do you have sufficient overhead clearance?

Check low roof eaves, overhanging branches, rain gutters

Is the path clear?

Move away branches, dog houses, firewood, etc.

If there is a 90° turn, can we clear it?
(The spa will not bend.)

No stairs! If there are stairs in the delivery route, consult the dealer.

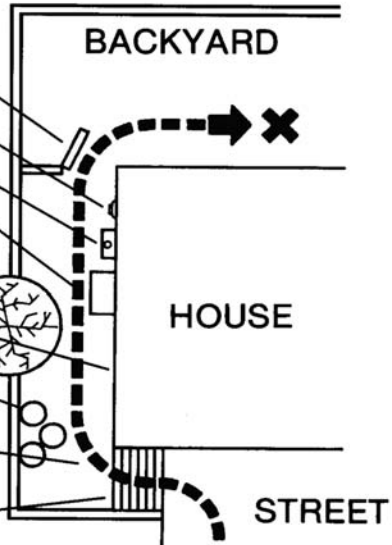

Electrical Requirements

Electrical Requirements – US and Canada

240 Volt Electrical Installation

All 240V spas must be permanently connected (hardwired) to the power supply. See the wiring diagram on page 9.

These instructions describe the only acceptable electrical wiring procedure. Spas wired in any other way will void your warranty and may result in serious injury.

When installed in the United States, the electrical wiring of this spa must meet the requirements of National Electric Code, ANSI/NFPA 70-2008 and any applicable local, state, and federal codes.

The electrical circuit must be installed by an electrical contractor and approved by a local building or electrical inspector.

Failure to comply with state and local codes may result in fire or personal injury and will be the sole responsibility of the spa owner.

GFCI and Wiring Requirements

The power supplied to the spa must be on a dedicated GFCI protected circuit as required by ANSI/NFPA 70 with no other appliances or lights sharing the power.

Use copper wire with THHN insulation. Do not use aluminum wire.

Use the table on the next page to determine your GFCI and wiring requirements.

When NEC requires the use of wires larger than #6 AWG, install a junction box near the spa and use #6 AWG wire between the junction box and the spa.

Wire runs over 85 feet must increase wire gauge to the next lower number. For example: A normal 50 amp GFCI with four #8 AWG Copper wires run over 85 feet would require you to go to four #6 AWG copper wires.

Read and follow the heater manufacturer's safety and installation instructions prior to installation and operation. Incorrect installation may damage the heater and void its warranty.



	Spa Model	GFCI Required	Wires Required
Portable Spas	All 240V spas (except 6300 control boxes requiring high amperage - see below)	One 50 amp GFCI	Four #8 AWG copper wires
	Spas with the 6300 control box (when high amperage is selected on circuit board) SEE CONFIGURATION INSTRUCTIONS ON NEXT PAGE.	One 60 amp GFCI	Four #8 AWG copper wires

Ultimate Fitness Spas	Fitness spa with 5.5 kW heater: <i>F854, F1257, FP2400</i>	One 50 amp GFCI	Four #8 AWG copper wires
	Fitness spa with 11 kW heater: <i>F1257, F1455, FP1655, FP2500, FP2400</i> SEE PAGES 8 AND 9 FOR INSTALLATION DIAGRAM.	Service 1: One 60 amp GFCI Service 2: One 30 amp GFCI	Service 1: Four #8 AWG copper wires Service 2: Three #8 AWG copper wires
	Fitness Pro 4700 spa SEE PAGES 8 AND 9 FOR INSTALLATION DIAGRAM.	Service 1 (swim side): One 60 amp GFCI Service 2 (swim side): One 30 amp GFCI Service 3 (spa side): One 40 amp GFCI	Service 1: Four #8 AWG copper wires Service 2: Three #8 AWG copper wires Service 3: Four #8 AWG copper wires

Testing the GFCI Breaker

Test the GFCI breaker prior to first use and periodically when the spa is powered. To test the GFCI breaker follow these instructions (spa should be operating):

1. Press the TEST button on the GFCI. The GFCI will trip and the spa will shut off.
2. Reset the GFCI breaker by switching the breaker to the full OFF position, wait a moment, then turn the breaker back on. The spa should have power again.

Configuring the 6300 Control System

The 6300 control system requires higher power than other 240V systems. Dip switch #10 is factory set in the ON position. This causes the heater to shut off when any pump is running in high speed. To allow the heater to continue operating, dip switch #10 must be set to the OFF position.

To ensure your spa functions properly, ensure the following steps are performed before starting your spa:

- When installing the electrical system, use a 60 amp GFCI. Follow the GFCI wiring diagram on the next page.
- Have your dealer or installer set dip switch #10 to the OFF position on the circuit board as shown below.

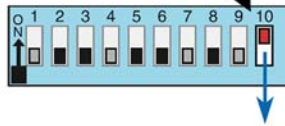
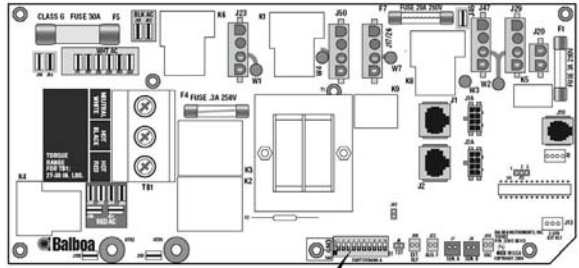

Set dip switch 10 to OFF position

Electrical Installation for 11 kW Heater

This applies to Fitness spas with the 11 kW heater only.

Two electrical services are required to heat the swim side of the Fitness Spa.

SOURCE #2
INPUT POWER 30AMPS
3 WIRES
HOT, HOT, GROUND
AWG #8

SOURCE #1
INPUT POWER 60 AMPS
4 WIRES
HOT, HOT, NEUTRAL GROUND
AWG #8

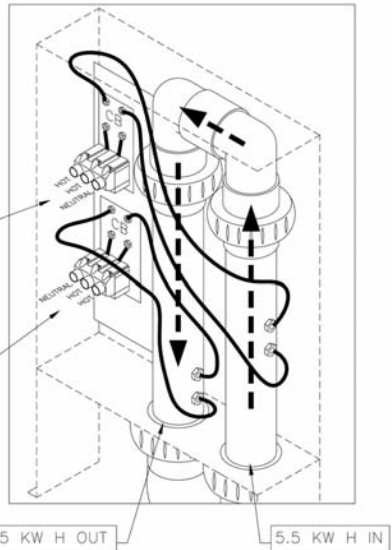

GFCI Wiring Diagram

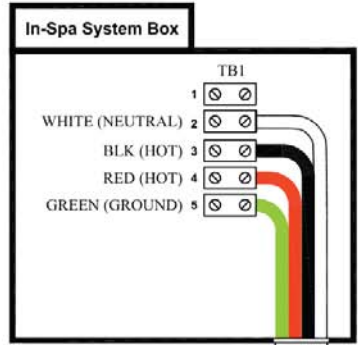
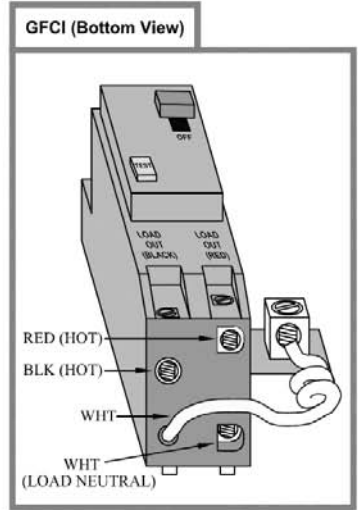
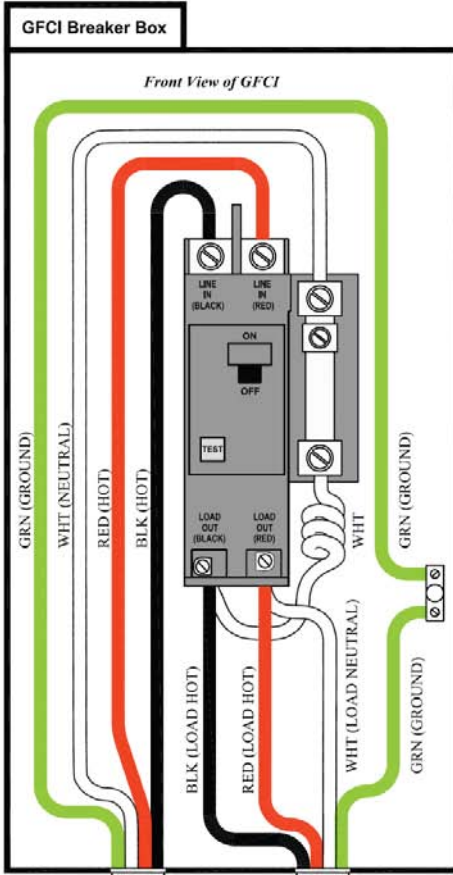
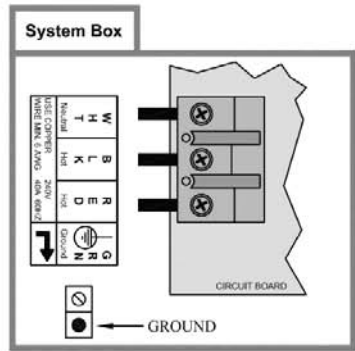
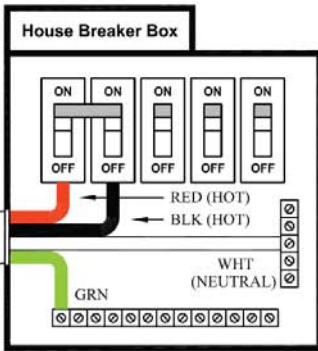

120 Volt Electrical Installation

Always follow applicable local, state and federal codes and guidelines.

Use only a dedicated electrical line with a 20-amp breaker.

Cord-and-plug connections may not use a cord longer than 15 ft (4.6 m) and must be plugged into a dedicated 20-amp GFCI connection. Do not use extension cords!

Always use a weatherproof-covered receptacle.

Receptacle shall be located not less than 5 ft (1.5 m) from and not exceeding 10 ft (3.0 m) from the inside wall of the spa.

Do not bury the power cord.

If your cord becomes damaged, replace it before next usage.

All 120V spas must have a GFCI. This can be either a 20-amp GFCI receptacle or a GFCI cord and plug kit as shown at right (CKIT110 - P/N ELE09700086).



Testing the GFCI Breaker

Test the GFCI plug prior to first use and periodically when the spa is powered. To test the GFCI plug version, follow these instructions. (Spa should already be plugged in and operational.)

1. Press the TEST button on the GFCI. The GFCI will trip and the spa will stop operating.
2. Press the RESET button on the GFCI. The GFCI will reset and the spa will turn back on.

The spa is now safe to use.

If the GFCI trips while the spa is in use, press the RESET button. If the GFCI does not reset, unplug the spa and call your local Cal Spas dealer for service. **DO NOT USE THE SPA!**

Electrical Installation -- Europe

230 Volt Electrical Installation

All 230V spas must be permanently connected (hardwired) to the power supply. These instructions describe the only acceptable electrical wiring procedure. Spas wired in any other way will void your warranty and may result in serious injury.

This is the only acceptable electrical wiring procedure. Spas wired in any other way will void your warranty. See the wiring diagram on page 13.

The electrical wiring of this spa must meet the requirements of any applicable local, state, and federal codes. The electrical circuit must be installed by an electrical contractor and approved by a local building / electrical inspector.

RCD and Wiring Requirements

The power supplied to the spa must be on a dedicated RCD protected circuit with no other appliances or lights sharing the power.

Use copper wire with THHN insulation. Do not use aluminum wire.

Use the table on the next page to determine your GFCI and wiring requirements.

When wires larger than #6 AWG are required, install a junction box near the spa and use #6 AWG wire between the junction box and the spa.

Wire runs over 85 feet must increase wire gauge to the next lower number. For example: A normal 50 amp RCD with four #8 AWG copper wires run over 85 feet would require you to go to four #6 AWG copper wires.



Testing the RCD Breaker

Test the RCD breaker prior to first use and periodically when the spa is powered. To test the RCD breaker follow these instructions (spa should be operating):

1. Press the TEST button on the RCD. The RCD will trip and the spa will shut off.
2. Reset the RCD breaker by switching the breaker to the full OFF position, wait a moment, then turn the breaker back on. The spa should have power again.

	Spa Model	GFCI Required	Wires Required
Portable Spas	All 230V spas (except 6205 control boxes requiring high amperage - see below)	One 32 amp RCD or two 16 amp RCDs	Three #10 AWG copper wires
	Spas with the 6300 control box (when high amperage is selected on circuit board) SEE CONFIGURATION INSTRUCTIONS ON NEXT PAGE.	One 32 amp RCD or two 16 amp RCDs	Three #10 AWG copper wires

Ultimate Fitness Spas	F2400 spas with one 5.5 kW heater	One 32 amp RCD or two 16 amp RCDs	Three #10 AWG copper wires
	FP2500 spa with one 5.5 kW heater and one 3 kW heater	Service 1: One 32 amp RCD or two 16 amp RCDs Service 2: One 32 amp RCD	Service 1: Three #10 AWG copper wires Service 2: Three #10 AWG copper wires
	FP4700 spa	Service 1 (swim side): One 32 amp RCD Service 2 (swim side): One 32 amp RCD Service 3 (spa side): One 32 amp RCD	Service 1: Three #10 AWG copper wires Service 2: Three #10 AWG copper wires Service 3: Three #10 AWG copper wires

RCD Wiring Diagram

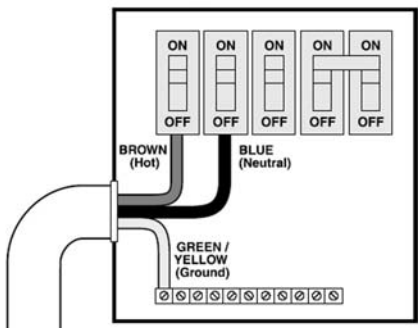

Value M-7 and 2000LE M-7 System

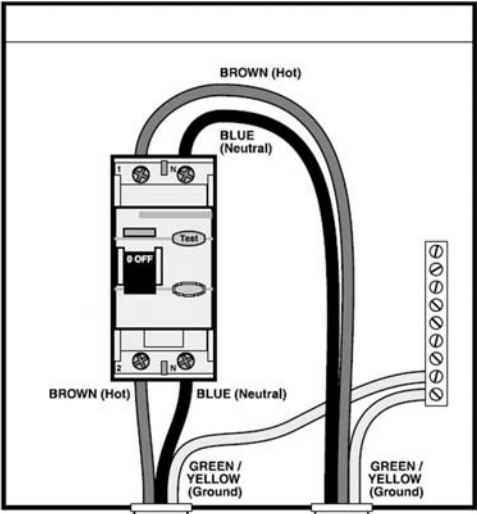
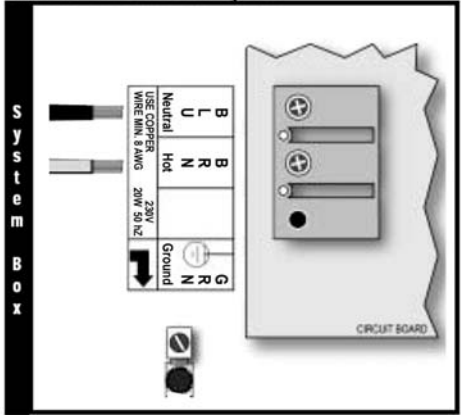

Elite System

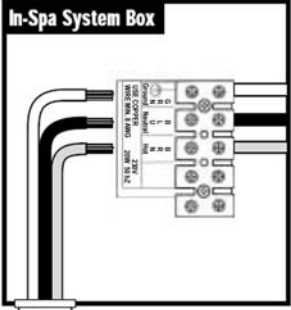

Spa Technical Specifications

All sizes on this chart represent outside dimensions. Due to our continuous improvements, specifications, size and pricing are subject to change without prior notice.

Avalon Series						
Model	Width	Length	Depth	Gallons	Dry Weight	Filled Weight
A515	84"	64"	32"	325	600 Lbs.	3307 Lbs.
A526	84"	64"	32"	325	600 Lbs.	3307 Lbs.
A534	84"	64"	32"	325	600 Lbs.	3307 Lbs.
A726B	84"	84"	39½"	425	850 Lbs.	4390 Lbs.
A726L	84"	84"	39½"	425	850 Lbs.	4390 Lbs.
A734B	84"	84"	39½"	425	850 Lbs.	4390 Lbs.
A734L	84"	84"	39½"	425	850 Lbs.	4390 Lbs.
A744B	84"	84"	39½"	425	850 Lbs.	4390 Lbs.
A744L	84"	84"	39½"	425	850 Lbs.	4390 Lbs.
A826B	93"	93"	39½"	450	900 Lbs.	4648 Lbs.
A826L	93"	93"	39½"	450	900 Lbs.	4648 Lbs.
A834B	93"	93"	39½"	450	900 Lbs.	4648 Lbs.
A834L	93"	93"	39½"	450	900 Lbs.	4648 Lbs.
A844B	93"	93"	39½"	450	900 Lbs.	4648 Lbs.
A844L	93"	93"	39½"	450	900 Lbs.	4648 Lbs.
A857B	93"	93"	39½"	450	900 Lbs.	4648 Lbs.
A857L	93"	93"	39½"	450	900 Lbs.	4648 Lbs.
A969L	93"	130"	39½"	800	1200 Lbs.	7864 Lbs.

Designer Series						
Model	Width	Length	Depth	Gallons	Dry Weight	Filled Weight
DI-401	93"	Round	34"	500	500 Lbs.	4665 Lbs.
DI-405	130"	93"	33"	900	750 Lbs.	8247 Lbs.
DI-407	93"	202"	48½"	2500	1300 Lbs.	22125 Lbs.

Classic Series						
Model	Width	Length	Depth	Gallons	Dry Weight	Filled Weight
CL-25	64"	84"	32"	125	535 Lbs.	1576 Lbs.
CP-36	84"	84"	39½"	425	850 Lbs.	4390 Lbs.
CT-36	84"	84"	39½"	425	850 Lbs.	4390 Lbs.
CP-50	84"	84"	39½"	425	850 Lbs.	4390 Lbs.
CT-50	84"	84"	39½"	425	850 Lbs.	4390 Lbs.
CT-64	84"	84"	39½"	425	850 Lbs.	4390 Lbs.
CP-65	84"	84"	39½"	425	850 Lbs.	4390 Lbs.
CV-35	93"	84"	39½"	450	900 Lbs.	4648 Lbs.
CA-65	93"	93"	39½"	450	900 Lbs.	4648 Lbs.
CA-36	93"	93"	39½"	450	900 Lbs.	4648 Lbs.
CBA-36	93"	93"	39½"	450	900 Lbs.	4648 Lbs.
CD-46	93"	93"	39½"	450	900 Lbs.	4648 Lbs.
CM-47	93"	93"	39½"	450	900 Lbs.	4648 Lbs.
CA-50	93"	93"	39½"	450	900 Lbs.	4648 Lbs.
CBA-50	93"	93"	39½"	450	900 Lbs.	4648 Lbs.
CBA-64	93"	93"	39½"	450	900 Lbs.	4648 Lbs.
CN-50	93"	130"	39½"	800	1200 Lbs.	7864 Lbs.
CN-65	93"	130"	39½"	800	1200 Lbs.	7864 Lbs.
CE-57	93"	138"	39½"	900	1100 Lbs.	8595 Lbs.

Galaxy Series						
Model	Width	Length	Depth	Gallons	Dry Weight	Filled Weight
GX-49	93"	93"	39½"	450	900 Lbs.	4648 Lbs.

Escape Series						
Model	Width	Length	Depth	Gallons	Dry Weight	Filled Weight
EIII732B	84"	84"	39½"	425	800 Lbs.	4340 Lbs.
EIII732L	84"	84"	39½"	425	800 Lbs.	4340 Lbs.
EIII748L	84"	84"	39½"	425	800 Lbs.	4340 Lbs.
EIII848L	93"	93"	39½"	450	900 Lbs.	4650 Lbs.
EIII864L	93"	93"	39½"	450	900 Lbs.	4650 Lbs.

Family II Series						
Model	Width	Length	Depth	Gallons	Dry Weight	Filled Weight
F515R	78"	Round	36"	300	350 Lbs.	2849 Lbs.
F518S	43"	83"	32"	100	250 Lbs.	1083 Lbs.
F520B	54"	78"	31"	125	350 Lbs.	1391 Lbs.
F730B	84"	84"	35"	425	800 Lbs.	4340 Lbs.
F730L	84"	84"	35"	425	800 Lbs.	4340 Lbs.
F732B	84"	84"	35"	425	800 Lbs.	4340 Lbs.
F732L	84"	84"	35"	425	800 Lbs.	4340 Lbs.
F745B	84"	84"	35"	425	800 Lbs.	4340 Lbs.
F745L	84"	84"	35"	425	800 Lbs.	4340 Lbs.
F748L	84"	84"	35"	425	800 Lbs.	4340 Lbs.
F830B	93"	93"	35"	450	900 Lbs.	4648 Lbs.
F830L	93"	93"	35"	450	900 Lbs.	4648 Lbs.
F845B	93"	93"	35"	450	900 Lbs.	4648 Lbs.
F845L	93"	93"	35"	450	900 Lbs.	4648 Lbs.
F848L	93"	93"	35"	450	900 Lbs.	4648 Lbs.
F864L	93"	93"	35"	450	900 Lbs.	4648 Lbs.

Ultimate Fitness and Fitness Pro Series						
Model	Width	Length	Depth	Gallons	Dry Weight	Filled Weight
F854	93"	93"	52"	650	1500 Lbs.	6914 Lbs.
F1257	96"	144"	52"	2000	1600 Lbs.	18260 Lbs.
FP1455	96"	174"	52"	2500	2000 Lbs.	22825 Lbs.
FP1755	96"	203"	52"	2500	2000 Lbs.	22825 Lbs.
F2400	96"	170"	52"	2000	1800 Lbs.	18460 Lbs.
FP2500	96"	206"	51"	2500	2000 Lbs.	22825 Lbs.
FP4700	96"	202"	52"	2000 / 285	2950 Lbs.	21985 Lbs.

Victory Extreme Series						
Model	Width	Length	Depth	Gallons	Dry Weight	Filled Weight
VX-901	72"	72"	30"	130	600 Lbs.	1583 Lbs.
VX-624B	76"	84"	34"	325	730 Lbs.	3437 Lbs.
VX-724L	78"	84"	32"	340	740 Lbs.	3572 Lb.s
VX-726B	84"	84"	39½"	425	800 Lbs.	4340 Lbs.
VX-726L	84"	84"	39½"	425	800 Lbs.	4340 Lbs.
VX-740L	84"	84"	39½"	425	800 Lbs.	4340 Lbs.
VX-834B	93"	93"	39½"	425	800 Lbs.	4340 Lbs.
VX-834L	93"	93"	39½"	425	800 Lbs.	4340 Lbs.
VX-848L	93"	93"	39½"	425	800 Lbs.	4340 Lbs.
VX-848B	93"	93"	39½"	450	900 Lbs.	4648 Lbs.
VX-861B	93"	93"	39½"	450	900 Lbs.	4648 Lbs.
VX-861L	93"	93"	39½"	450	900 Lbs.	4648 Lbs.



LMS Customer Service Department
1462 East Ninth Street
Pomona, CA 91766

Toll Free: 1-800-CAL-SPAS
Fax: 1-909-629-3890

www.calspas.com