

Deluxe Spa Step Assembly

#WOOD118-KD, All Models



Cal Spas Home Resort™

These instructions describe the step-by-step procedure for assembling the two-tier spa step. Before beginning, check the parts that came with your step package to ensure everything you need is present.

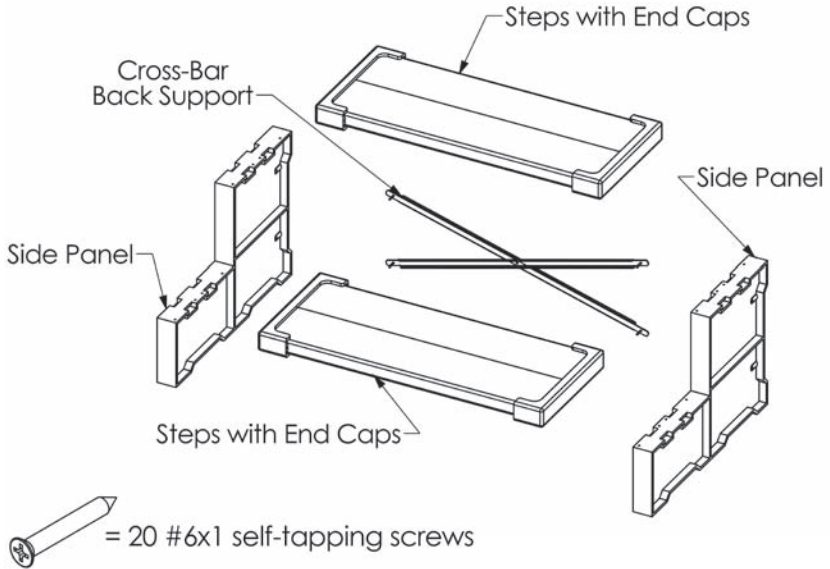

Tools Required



Cordless/Electrical Drill



1/8" Drill bit



Screwdriver bit (Phillips)



Screwdriver (Phillips)

Step # 1

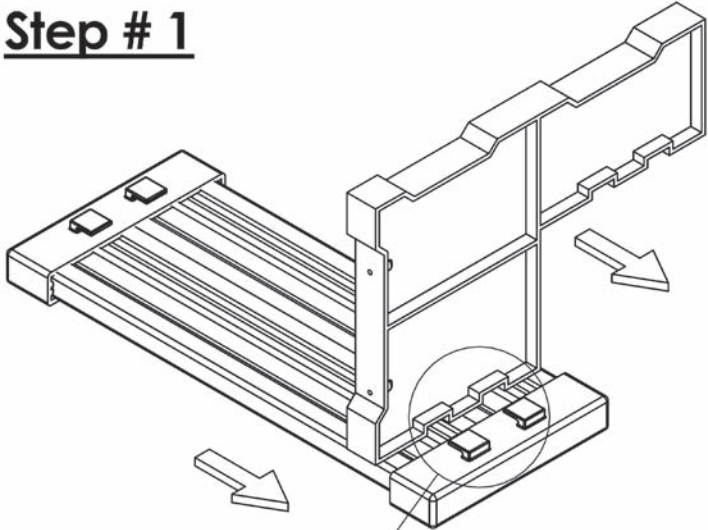

Slide the plastic tabs on the underside of each step into the slots in the side panels.

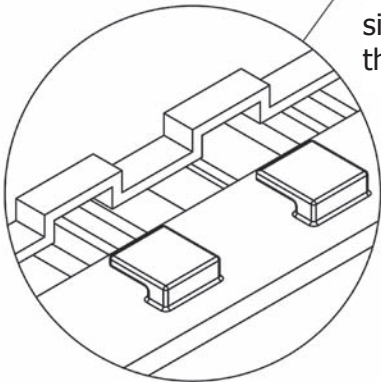

Step # 2

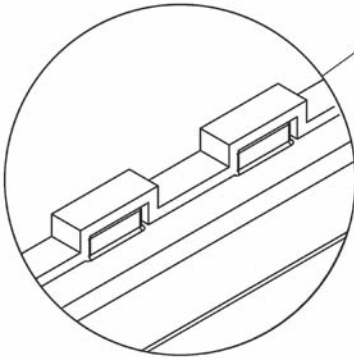
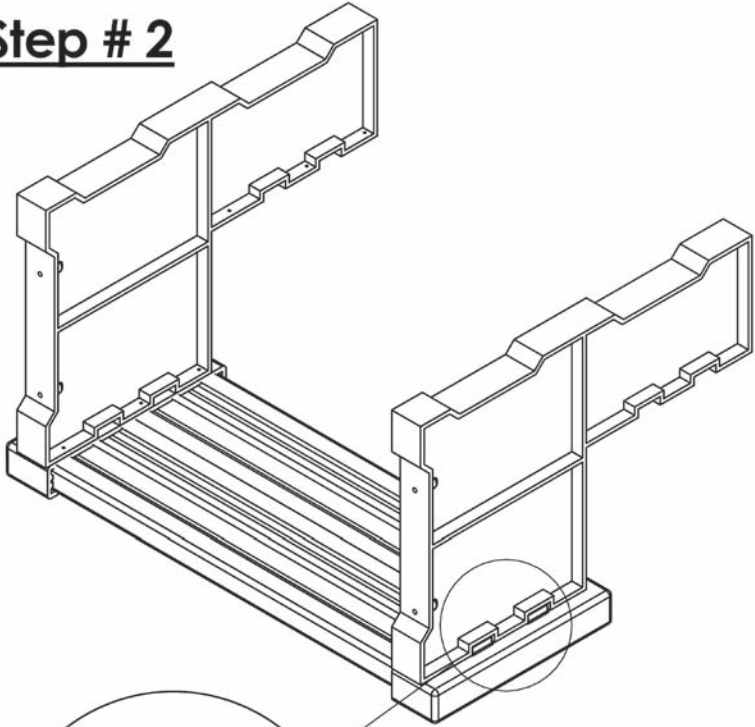

Tap the step and side panels together until they are flush.

Step # 3

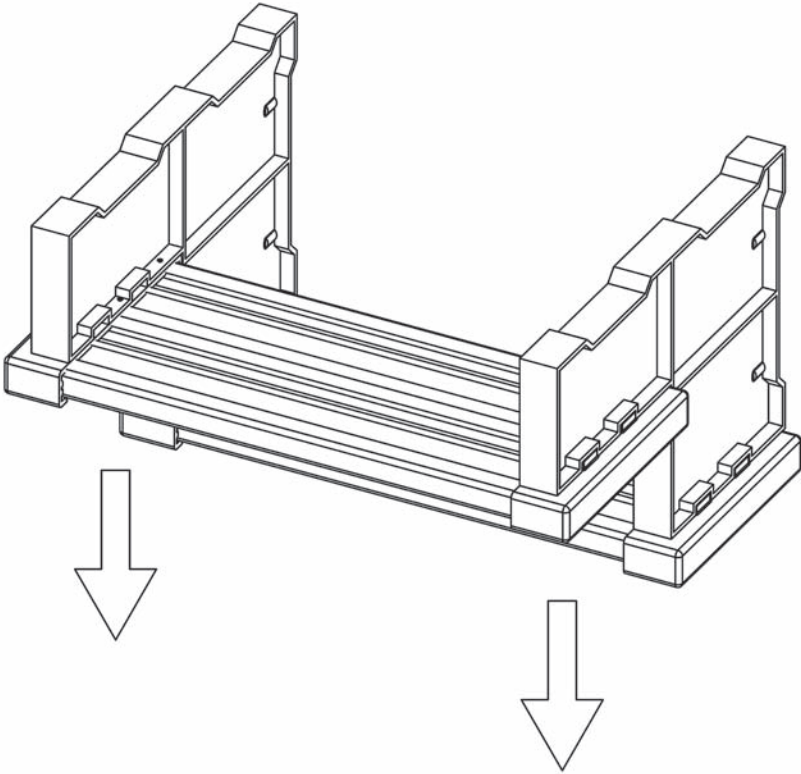

Place step upside down on a level surface for support.

Step # 4

Tools Needed:



OR

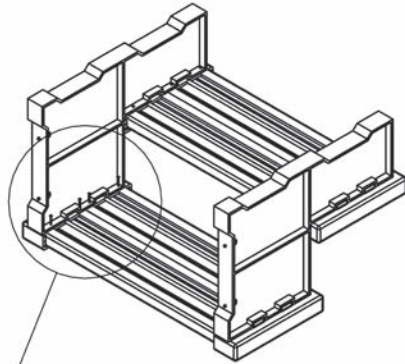

Insert four self-tapping screws
on the bottom side of the step.
Do this for all four sides.

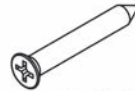
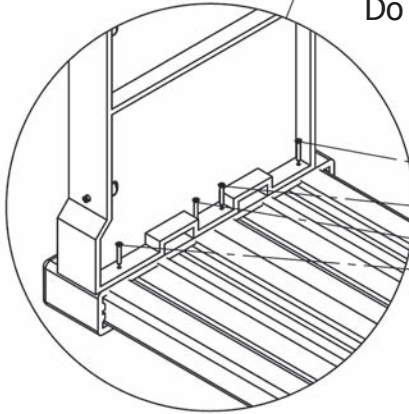

Self-tapping
screws

Step # 5

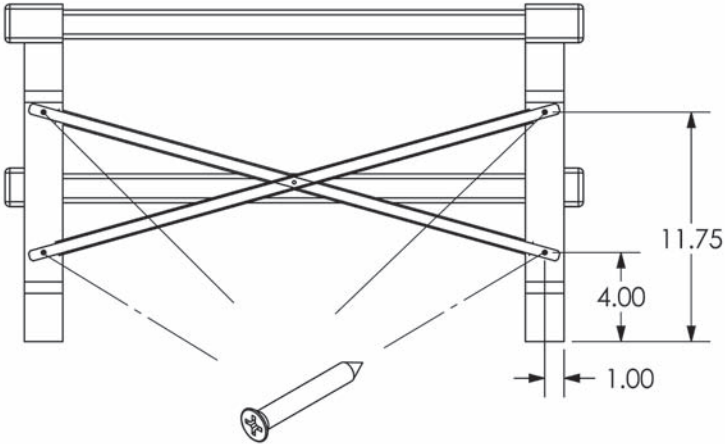

Self-tapping screw

Turn the step right side up.

Drill pilot holes for the screws using the 1/8" drill bit at the distances shown.

Attach the cross-bar back support with four self-tapping screws.

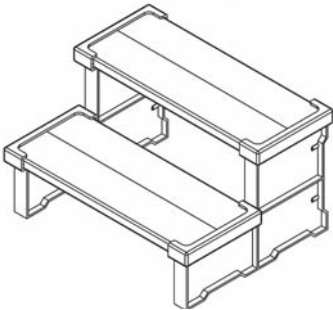

CONTACT INFORMATION

For customer service, please contact your authorized dealer immediately. If you need additional information and/or

assistance, please contact:
Customer Service Department

1462 East Ninth Street
Pomona, CA 91766

Toll Free: 1-800-CAL-SPAS

Fax: 1-909-629-3890

www.calspas.com

Copyright 2009 LMS, Inc. All rights reserved. Duplication without written consent is strictly prohibited.

Cal Designs ® is a registered trademark.

Due to continuous improvement programs, all models, operation, and/or specifications are subject to change without prior notice.

LTR20091081, Rev. A
4/24/09