



2009 OWNER'S MANUAL

United States and Canada

Side Burners

Manufactured after December 22, 2008

© 2009 LMS, Inc.



Cal Spas Home Resort™

www.calspas.com



Installation / Assembly

Cabinet Cut-out Dimensions	4
Gas Requirements and Connection	5
Leak Testing Procedure	6
LP Gas	7
Natural Gas	9
Installing Side Burner with a Grill	10

Using Your Side Burner

Lighting the Side Burner	12
Basic Side Burner Operation	14

Cleaning and Maintenance

Stainless Steel Care and Cleaning	15
Covering Your Side Burner	18

Appendix

Troubleshooting	19
Converting Side Burner from LP to NG	21
2009 Warranty	22

Save these instructions!

Copyright 2008-2009 LMS, Inc. All rights reserved. Duplication without written consent is strictly prohibited.

Cal Flame ® is a registered trademark.

Due to continuous improvement programs, all models, operation, and/or specifications are subject to change without prior notice.

LTR20091082, Rev. A
6/15/09

California Proposition 65 Warning: Chemicals known to the State of California to cause cancer, birth defects or other reproductive harm are found in and/or created by the combustion of natural gas, propane, butane and other fuels. Always operate this unit as described in the owner's manual and in well ventilated areas.

Safety Instructions

WARNING: Improper installation, adjustment, alteration, service or maintenance can cause injury or property damage. Read the installation, operating and maintenance instructions thoroughly before installing or servicing this equipment.

Placement and Location

- **Cal Flame side burners are designed for outdoor use only.**
- Never locate this appliance in an enclosed room, under a sealed overhead structure, or in any type of enclosed area such as a garage, shed, or breezeway. Keep clear of trees and shrubs.
- Do not place a side burner under or near windows or vents that can be opened into your home.
- Cal Flame side burners are not intended for installation in or on recreational vehicles or boats.
- Maintain sufficient distance as to not overheat any overhead combustible material such as a patio cover.
- The area surrounding your new side burner should be kept clean and free from flammable liquids and other combustible materials such as mops, rags or brooms, as well as solvents, cleaning fluids, and gasoline.
- Do not use the side burner or area surrounding the side burner as a storage area for flammable or plastic items. Do not store the liquid propane (LP) cylinder in the vicinity of this or any other appliance when it is not being used.

Set-Up

- We recommend that a licensed contractor install your Cal Flame side burner. Installation must conform to local codes, or in the absence of local codes, with either the *National Fuel Gas Code*, ANSI Z223.1 / NFPA54, *Natural Gas and Propane Installation Code*, CSA B149.1, or *Propane Storage and Handling Code*, B149.2), as applicable.
- To prevent fire and smoke damage, remove all packaging material before operating side burner.
- Before you start cooking, clean the entire side burner thoroughly with hot, soapy water. This is necessary to remove residual solvents, oil and grease used in the manufacturing process. The grates should also be thoroughly cleaned in the same manner.

Operation

- Do not use side burner for other than intended use.
- In the event that a burner goes out, turn burner knobs to the full OFF position and let it air out. Do not attempt to use the side burner until the gas has had time to dissipate.
- Keep all electrical supply cords and the rotisserie motor cord away from the heated areas of the side burner.
- Never use the side burner in windy conditions. If used in a consistently windy area a windbreak will be required. Always adhere to the specified clearances listed in this manual.
- Never line the side burner with aluminum foil.
- When the unit is not in use, be sure to turn off the gas at the source.
- When handling LP gas line and connectors, do not allow them to come in contact with any metal surfaces of the cart or cabinet. Do not drop LP connectors.
- Do not use solid fuel such as charcoal briquettes.
- Never leave the side burner unattended when in use. When using pots and pans, boil-overs will cause smoking and greasy boil-overs may ignite.
- Always use the proper size pan. Select utensils with flat bottoms large enough to cover the burner. The use of under-sized utensils exposes the sides of the utensils to direct contact with a portion of the flame. This can scorch utensils and hamper cleanup. Excessive flames on large stainless steel pots can result in permanent discoloration. For best results, we recommend commercial quality aluminum pans and utensils.
- Always position handles of utensils so they do not extend over adjacent work areas or cooking areas. This reduces the risk of burns, ignition of flammable materials, and spillage due to accidental contact with the utensils.
- Do not use water on grease fires. Never pick up a flaming pan. Turn the appliance off and smother the flaming pan with a tight-fitting lid, a cookie sheet or a flat tray. For flaming grease outside of the pan, smother it with baking soda or use a dry chemical or foam-type fire extinguisher.
- Never allow clothing, pot holders or other flammable materials come in contact with or be close to any grate, burner or hot surface until it has fully cooled. Never wear loose fitting or hanging

garments while using your side burner. Fabric may ignite and result in personal injury.

- Only use dry pot holders and do not use a towel or other bulky cloth in place of pot holders. Moist or damp pot holders used on hot surfaces can cause burns.
- Do not heat any unopened glass or metal container of food on the side burner. Pressure may build up and cause the container to burst, possibly resulting in serious personal injury or damage to the side burner.
- Do not reach over your side burner when hot or in use.

Maintenance and Repair

- Spiders and other insects can nest in the burners of the side burner and block the gas and airflow to the burner ports. This creates a dangerous condition that can result in a fire behind the valve panel. Inspect and clean the burners periodically and follow the guidelines in the Cleaning and Maintenance section of this manual.
- Unless specifically recommended in this manual, do not repair or replace any part of the side burner. A qualified technician should perform all service. Any repairs made by a non-L.M.S. approved dealer technician will void your warranty.

Storage

- When your side burner is not in use, turn off the gas at the supply cylinder.

Precautions Regarding Children

- Never leave children unattended in the area where the side burner is being used. Close supervision of children is necessary when any appliance is use near children.
- Do not store items of interest to children in the side burner.
- Never allow children to sit or stand on any part of the side burner.

Installation / Assembly

Most cities and counties require permits for exterior construction and electrical circuits. In addition, some communities have codes requiring residential barriers such as fencing and/or self-closing gates on property to prevent unsupervised access to the property by children under the age of five. Your dealer can provide information on which permits may be required and how to obtain them prior to the delivery of your equipment.

We recommend the installation, adjustment and service of your new side burner be performed by LMS qualified installers and service technicians to ensure proper operation and prevent accidents.

When planning your Cal Flame side burner location, access to gas lines should be considered. The location with the shortest gas line run is recommended.

When determining a suitable location, consider factors such as exposure to wind, proximity to traffic paths, and windows that open into the home.

Cabinet Cut-out Dimensions

Your Cal Flame side burner is designed for easy installation into a non-combustible enclosure. The supporting deck or counter must be flat and level. When determining the final location of your side burner, adequate cross ventilation must be present to prevent gas from being trapped in the event of a leak.

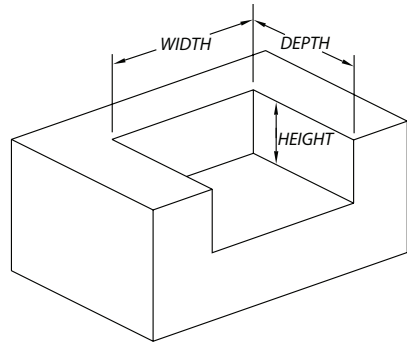

The drawings below show the different types of cabinet cut-out dimensions for side burners.

Model	Description	Width	Depth	Height
BBQ08898P	Deluxe Single Side Burner	12 1/8"	21 3/4"	7 1/4"
BBQ08899P	Deluxe Double Side Burner	12 3/8"	21 3/4"	7 1/4"
BBQ08954P	Deluxe Side by Side Burner	25 1/4"	13 1/4"	7 1/4"

Gas Requirements and Connection

Gas Requirements and Connection

IMPORTANT: The Cal Flame side burner is manufactured to operate on liquid propane (LP). However, it can be converted to operate on natural gas (NG) by an authorized service technician. Consult your Cal Flame dealer for information on converting your side burner.

Owners must not convert their side burners themselves. Attempting to convert the side burner from LP to NG may result in serious injury and will void the warranty coverage.

If you do not have an updated filler valve on your existing propane tank, you will need to purchase one at your local hardware store. Without it you will not be able to attach your tank to your Cal Flame side burner or refill the tank at your local propane refill station.

Leak Testing Procedure

Perform a leak test at least once a year whether the gas supply cylinder has been disconnected or not. In addition, whenever the gas cylinder is connected to the side burner or whenever any part of the gas system is disconnected or replaced, perform a leak test.

As a safety precaution, remember to always leak test your side burner outdoors in a well-ventilated area. Never smoke or permit sources of ignition in the area while doing a leak test. Do not use a flame, such as a lighted match to test for leaks. Use a solution of soapy water.

1. Prepare a leak testing solution of soapy water by mixing in a spray bottle one part liquid soap to one part water.
2. Make sure all the control knobs are in the OFF position.
3. Turn on the gas.
4. Apply the leak-testing solution by spraying it on joints of the gas delivery system. Blowing bubbles in the soap solution indicates that a leak is present.
5. Stop a leak by tightening the loose joint or by replacing the faulty part with a replacement part recommended by the manufacturer. Do not attempt to repair the cylinder valve if it is damaged. The cylinder must be replaced.
6. Turn all control knobs back to the full OFF position.

If you are unable to stop a leak:

1. Turn all control knobs back to the full OFF position.
2. Shut off the gas supply to the side burner and release pressure in the hose and manifold by pushing in and turning any of the control valves one quarter turn counter-clockwise.
3. On LP systems, remove the cylinder from the side burner.
4. Call an authorized gas appliance service technician or an LP gas dealer.

Do not use the appliance until the leak is corrected.

LP Gas

Tank Requirements

For plumbed-in LP installation, use a convertible regulator and set it for LP gas.

Maximum line pressure for plumbed-in propane is 14" WC (3.5 kPa). Minimum line pressure for propane is 11" WC.

The side burner unit must be used with the gas pressure regulator. The regulator will control and maintain a uniform gas pressure in the manifold. The burner orifices have been sized for the gas pressure delivered by the regulator.

WARNING: Attempting to operate the side burner unit without the gas regulator installed could cause an explosion and possible death.

Cylinder Specification

Any LP gas supply cylinder used with this side burner must be:

- Constructed and marked in accordance with the *Specifications for LP-Gas Cylinders* of the U.S. Department of Transportation or the National Standard of Canada, *CAN/CSA-B339, Cylinders, Spheres and Tubes for Transportation of Dangerous Goods; and Commission*, as applicable.
- Approximately 12 inches in diameter and 18 inches high.

The maximum fuel capacity is 20 lbs. of propane, or 5 gallons. Full cylinder weight should be approximately 38 lbs. (43.7 lbs. nominal water capacity.) Never fill the cylinder beyond 80% full.

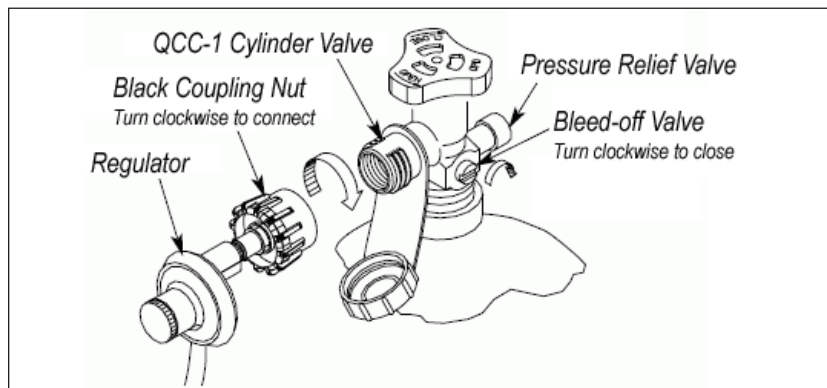

Place the dust cap on the cylinder valve outlet whenever the cylinder is not in use. Only install the type of dust cap on the cylinder valve outlet that is provided with the cylinder valve. Other types of caps or plugs may result in leakage of propane.

LP Gas Hook Up

An enclosure for an LP gas cylinder shall be vented by openings at the level of the cylinder valve and at floor level. The effectiveness of the openings for purposes of ventilation shall be determined with the LP-gas supply cylinder in place. This shall be accomplished in one of the following manners:

1. One side of the enclosure shall be completely open.
2. Enclosures that have four sides, complete with a top and bottom:
 - a. At least two ventilation openings at cylinder valve level shall be provided in the sidewall, equally sized, spaced at 180° (3.14 rad), and unobstructed. Each opening shall have a total free area of not less than one square inch per pound (7.1 cm²/kg) of stored fuel capacity, and not less than a total free area of 10 square inches (64.5 cm²).
 - b. Ventilation openings shall be provided at floor level and shall have a total free area of not less than one square inch per pound (7.1 cm²/kg) of stored fuel capacity and not less than a total free area of 10 square inches (64.5cm²). If ventilation openings at floor level are in a sidewall, there shall be at least two openings. The bottom of the openings shall be at floor level and the upper edge no more than 5 inches (127 mm) above the floor. The openings shall be equally sized, spaced at 180° (3.14 rad) and unobstructed.
 - c. Every opening shall have minimum dimensions so as to permit the entrance of a 1/8 inch (3.2 mm) diameter rod.

Transporting and Storing LP Gas

Transport only one cylinder at a time. Ensure the cylinder is secured in an upright position with the control valve turned off and the dust cap in place. Store cylinders outdoors and out of reach of children. Do not store cylinders in a building, garage, or any other enclosed area.

Natural Gas

Requirements

The installation of this appliance must conform with local codes or, in the absence of local codes, to the national fuel gas code, ANSI Z223.1a-1998. Installation in Canada must be in accordance with the standard CAN/CGA-B149.2, Propane Installation Code.

A licensed contractor or local gas company representative must perform all natural gas connections.

Ensure that the service supplying the side burner is fitted with a shut off valve conveniently positioned near the side burner and giving ease of access.

The side burner must be isolated from the gas supply piping system by closing its individual manual shutoff valve during any pressure testing of the gas supply piping system at test pressures equal to or less than 0.5 psi (3.5 kPa).

The side burner and its individual shutoff valve must be disconnected from the gas supply piping system during any pressure testing of that system at test pressure in excess of 0.5 psi (3.5 kPa).

Connection

1. Slide the side burner forward to gain access to the gas connection point in the rear.
2. Connect a suitable flex connector to the gas connection point.
3. Check the side burner controls to ensure all control valves are in the full OFF position.
4. Turn on the main gas supply and check all connections for leaks using soapy water as described in the leak testing procedure section.

Warning: If you see bubbles in the soapy solution at any of the connections, turn off the gas supply and tighten the connection. If tightening the connection does not seal the leak, it may be necessary to replace the flex hose.

Installing Side Burner with a Grill

If you are installing a side burner in conjunction with a gas grill, install it in the following manner.

1. Assemble a 3/8" pipe nipple to the 3/8" pipe tee using Teflon tape or pipe sealant. Use only sealant that is approved for use on LP gas.
2. Install the pipe tee assembly to the grill intake pipe. Tighten assembly and align the branch opening of the tee with the hole of the cabinet.
3. Connect the flexible hose (male end) to the pipe tee.
4. Install and secure the side burner into the island by simply setting it in place.
5. Connect the female end of the flexible hose to the side burner intake pipe.
6. Connect gas supply to the grill.
7. Check for gas leaks using soap water solution.

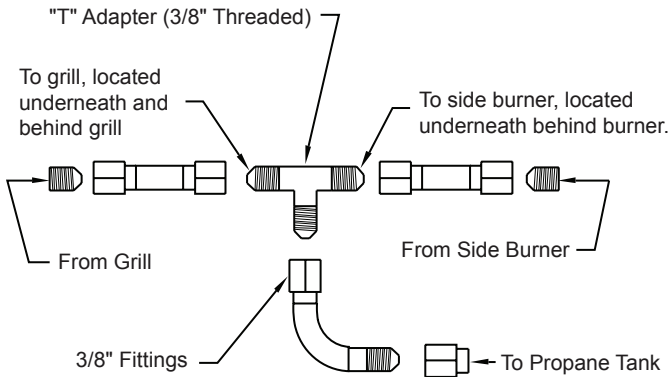

NOTE: You will need to use a gas rated sealer on gas connectors that are not flared.

- (A) Open barbecue door. Install hose with regulator on propane tank. Then connect the other end to "T" adapter. Make sure to use gas rated tape seal when installing adapter to insure proper seal.

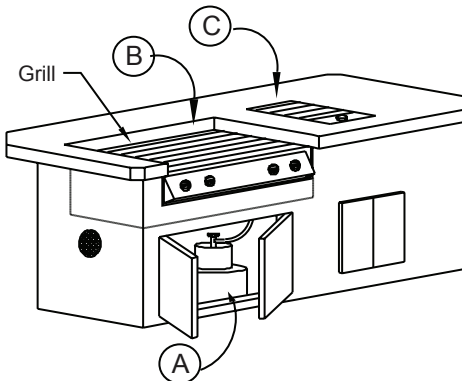

- (B) Then take other end of "T" adapter with hose attached and connect to end of male located underneath and at the back of the grill. (Use gas rated tape seal on all connections).
- (C) Connect the last open line to the side burner (Use gas rated tape seal on all connections)

Using Your Side Burner

Read all instructions before you operate your side burner.

We recommend you wash your side burner with soap and water prior to lighting it for the first time. Oils are used during the manufacturing process and some residual oil may still be on the stainless steel parts of your side burner. Washing will reduce the possibility of discoloration. We also recommend you keep your side burner covered when not in use. This will minimize the amount of dust and dirt that accumulates on your side burner and extend the life of your side burner.

Remember to use your Cal Flame side burner safely by following these reminders:

- It is dangerous to use side burners in any manner other than for what it is designed for.
- Do not use charcoal in a side burner.
- Do not heat sealed containers such as cans or jars on side burners. Explosion may result resulting in injury or death. Any sealed container, such as a pressure cooker, must have a properly operating pressure relieve valve to minimize explosion hazard.
- Never put combustible material such as paper, cloth, or flammable liquids on your side burner at any time. Do not use the side burner to store flammable materials.

Lighting the Side Burner

Each time you light the side burner, check the following:

- Inspect the hose before using the side burner. If there is excessive abrasion or wear, or if the hose is cut, it must be replaced prior to using the side burner. If you need a replacement hose, contact your Cal Flame dealer.
- Ensure the area around the barbecue is clear of flammable substances such as gasoline, yard debris, wood, etc.
- Ensure there is no blockage of the airflow through the vent space located below the face of the unit.
- When using propane gas:
 - **Keep the special ventilation openings in the enclosure free and clear of debris.**

- **If connected to a propane cylinder, carefully inspect the rubber hose attached to the regulator before each use.**
- **Ensure the propane cylinder, regulator, and rubber hose are installed in a location not subject to heating above 125° F (51° C).**
- Ensure the burner flames burn evenly along both sides of each burner with a steady flame (mostly blue with yellow tipping). If burner flames are not normal, check the orifice and burner for insects or insect nests.
- Ensure the in-line gas valve or gas cylinder valve is always shut OFF when the side burner is not in use.
- Do not operate the side burner with its cover closed or the back burner with its cover installed.

Electronically Lighting the Side Burners

1. Open the hood.
2. Keep your face as far away from the burners as possible.
3. Rapidly rotate the burner knob counter clockwise past the light position to HIGH. You will hear a loud click as the electronic lighter produces a spark.
4. Listen for the sound of the gas igniting. If the burner does not light on the first try, repeat immediately.
5. If the burner does not light after three attempts, turn the control knobs to the OFF position. Wait five minutes until the gas clears before attempting to light it again.
6. Repeat the procedure or try the manual lighting procedure below.
7. Upon successful lighting, repeat the process on the other burners you wish to light.
8. To shut off the burners, rotate the knob and turn to OFF. It is normal to hear a popping sound when the burners are turned off.

Manually Lighting the Side Burners

WARNING: Do not use standard matches or cigarette lighters to perform match lighting procedures. Serious burns can occur and lighters can explode.

1. Open the hood.
2. If you have just attempted to light the burner, allow five minutes for any accumulated gas to dissipate.
3. Keep your face as far away from the burners as possible.
4. Light and insert a long stem match, holding it near the burner ports.
5. Push in and turn the control knob just past the LIGHT position to HIGH.
6. Listen for the sound of the gas igniting. If the burner does not light after five seconds, turn the control knobs to the OFF position. Wait five minutes until the gas clears before attempting to light it again.
7. If the burner does not light after several attempts see Troubleshooting Guide in the back of this manual.

Basic Side Burner Operation

Before lighting, make sure all burner controls are off. Do not attempt to light the burners if the smell of gas is present. Check the connection with a soap and water solution after attaching the hose. For LP units, make sure there is gas in the tank and it is sitting upright. For natural gas units, make sure the shut off valve is on.

1. Light the side burners using the instructions on the previous page.
2. Place pots on the side burners and cook to desired completion. Adjust heat setting if necessary. You may set the control knob to any position between HIGH and LOW.

Do not leave the side burner unattended while cooking.

Cleaning and Maintenance

To ensure safe and proper maintenance, we recommend you follow these directions carefully.

Clean the side burner regularly as determined by the amount of use and foods cooked. In addition, keep the area around your side burner clear and free from combustible materials, gasoline, and other flammable vapors and liquids. Do not obstruct the flow of combustion and ventilation air.

These instructions describe the best way to care for your stainless steel.

Although stainless steel will discolor and accumulate grime with regular use, it can keep its original shine with periodic cleaning. We strongly recommend using a surface protectant to prevent smudging and surface rust from accumulating.

The easiest way to clean the side burner is immediately after cooking is completed. Doing so will extend the life of your side burner, prevent grease fires, and present a pleasant appearance while you cook.

Stainless Steel Care and Cleaning

All exposed stainless steel surfaces require special attention if you want to keep them looking clean and bright. Following these simple instructions will help avoid scratching or damaging the finish and keep your stainless steel attractive.

Cleaning Products and Materials

Avoid using these common cleaning products and materials – they will damage the surface of your stainless steel.

- CLR
- Lime-Away
- Oven cleaner
- Cleansers such as Ajax or Comet
- Ammonia
- Bleach
- Chlorine
- Steel wool pads
- Wire brushes
- Scrapers
- Pumice

We recommend these products for cleaning your stainless steel:

- Mild dish detergent such as Dawn
- Formula 409
- Fantastik
- Sheila Shine (exterior ONLY)
- WD-40 (exterior ONLY)

We have had best success with Sheila Shine, but WD-40 works very well too. Sheila Shine is available in some hardware stores; WD-40 is widely available.

Some people have reported that using baking soda, lemon oil, olive oil, vinegar, or club soda can be effective for cleaning light soil on all stainless steel surfaces.

Do not use steel wool or wire brushes to scrub your side burner. For light soil, use a damp sponge or cloth. For heavier stains, use a Scotch-Brite scrubber or similar product.

1. Clean

Thoroughly clean stains, food, and grime using a sponge or damp cloth with warm water and a mild dish soap. Use Fantastik or Formula 409 to remove heavier soil.

2. Rinse

Thoroughly rinse all surfaces and dry them completely with a clean towel. Do not allow stainless steel to air dry.

3. Polish

We strongly recommend that you apply a surface protectant to all exposed stainless steel surfaces.

Spray a small amount of WD-40 or Sheila Shine on a piece of paper towel and rub with the grain over the surface of the appliance. Using a clean terry cloth or paper towel, polish the appliance by rubbing with the grain until excess liquid is removed and the surface shines. It should not be oily to the touch, however some residue is acceptable.

Some people have reported that using lemon oil products such as Old English furniture polish is effective for polishing stainless steel and protecting the surface.



Caution

Do not use WD-40 or Sheila Shine near food or on food preparation surfaces as it is a health hazard.



Fire Hazard

NEVER spray WD-40 or Sheila Shine near an open flame! These products are extremely flammable while in their aerosol forms.



Note

Do not use a wire brush or stainless steel on any part of your side burner!

Rust Removal

It is a common misconception that stainless steel does not rust. It does not stain, corrode, or rust as easily as ordinary steel (it *stains less*), but it is not stain-proof. If not properly protected and maintained, it can corrode, pit, and discolor.



Important

Because salt will accelerate rust and corrosion, side burner owners who live near the beach need to be diligent in maintaining their stainless steel hardware. You need to clean and polish your stainless steel frequently, apply a protectant, and ensure water does not collect and puddle.

Periodically clean exterior stainless steel surfaces with WD-40 or Sheila Shine and wipe down with a dry cloth or paper towel until surface is free of rust. If there is significant rust or corrosion, use a Scotch-Brite scrubber.

Both of these products will act as a surface protectant and help resist smudges, stains, and rust.



Caution

Although nitric acid (also called aqua fortis) can be effective for rust removal, it is a highly corrosive chemical. Because of the potential for injury or damage to your stainless steel, we do not recommend using nitric acid.

Burner rack

The burner rack can all be removed for cleaning and is dishwasher safe.

Use a solution equal parts detergent and hot water just as you would for any cooking equipment. A stiff wire brush or steel wool may also be helpful in removing grime and food deposits.

Covering Your Side Burner

When not in use and after cooling, cover your side burner with our canvas cover. (See your local Cal Flame dealer for details.) The cover will help protect your side burner from detrimental effects of weather and environmental pollutants. Never put a cover on a hot side burner. Allow the side burner to cool before covering.

Appendix

Troubleshooting

Problem: Smell of gas is present

Solution: Check for loose connections in the gas line. Perform a leak test following the procedure described in this manual.

Problem: Burner does not ignite

Solution: Check the position of the sparker tip. It should be pointing forward towards the front of the burner.

- Make sure there is a blue spark at the electrode tip to the burner.
- Make sure the igniter wire is connected firmly to the valve ignition device and the electrode.
- Make sure the valve orifice is free of any debris, dust or grease.
- If there is no spark at all, replace the electrode or igniter wire.

Note: Turn off the gas at the source while troubleshooting.

Problem: Obstruction in the gas line

Solution: Remove the fuel line from side burner. (Do not smoke or perform any maintenance in the vicinity of an open flame.) Open the gas valve for one second to blow out any debris. Close off the gas valve and reconnect the fuel line securely.

Problem: Yellow Flame

Solution: Once the entire burner is operating, check the flame color to be sure that it is mostly blue. Some yellow at the tips may be present due to impurities in the fuel. If the flame is golden or yellow in color, the reason could be oil film, residue from boil over, or other foreign matter on the burner.

Problem: Plugged orifice**Solution:** Unplug the orifice as follows:

- Remove burner rack and brass burner.
- Using a 7mm socket or socket wrench, remove the brass orifice.
- Gently clear any obstruction with a fine wire.
- Reinstall the orifice and replace the burner racks.

If an obstruction is suspected in the control valve, contact your local Cal Flame dealer for assistance.

Problem: Misalignment of Igniter on Burner

- Solution:**
- Check for proper position of the electrode tip, which is next to, but does not touch, the brass burner. It should be pointing straight up and free of grease to allow proper sparking.
 - The ignition wire should be connected firmly to the valve ignition device and electrode. Reattach it if it has become disconnected. Replace the ignition wire if it is frayed or cracked.
 - With the gas supply closed and control knobs set to the off position, check each position igniter individually for the presence of a spark at the electrode. Push each knob in fully and rotate it about 1/4 turn to the left (counter-clockwise) until you hear a loud click. The trigger hitting the strike block should produce a blue spark at the electrode tip. Return control knob to the off position before checking the next igniter.

Converting Side Burner from LP to NG

When converting an LP side burner that is connected to an LP grill, you MUST convert both appliances.

It is dangerous to have an LP appliance and an NG appliance supplied by the same fuel.

WARNING! You must have an authorized service technician perform this procedure. If these instructions are not followed exactly, a fire or explosion may result causing property damage, personal injury or loss of life. Lloyd's Material Supply (LMS) will not be held responsible for an improperly converted gas side burner.

All Cal Heat side burners are manufactured to use standard liquid propane (LP) and can be converted to burn natural gas (NG).

You will need one or two orifices (depending on the size of the side burner), contained in the conversion kit provided with the side burner. The conversion kit contains orifices to convert five main burners, two small rear infrared burners, one large infrared burner, and two side burners. You will not need all of the parts in the kit.

Before you begin, make certain the LP gas source has been disconnected.

Replacing the side burner orifices

1. Remove the grate, burner cap and burner diffuser from the side burner.
2. Using a 7mm wrench, remove the orifice for the burner.
3. Apply a small amount of pipe compound to the orifice threads.
4. Screw in the orifice until it is finger tight.
5. Tighten the orifice with the 7mm wrench.
6. If you have dual side burners, repeat the previous steps for the second burner.

2009 WARRANTY

LMS offers the following limited warrants against defects in material and workmanship on Cal Flame barbecue products and components:

One Year Warranty

LMS warrants against deterioration and corrosion all parts, equipment and construction for a period of one year.

Extent of Warranty

This warranty is only valid on Cal Flame side burners delivered in the United States or Canada and extends through the selling dealer to the original purchaser at the original site of installation. This warranty becomes valid at time of purchase and ends either by specified time-frame listed above or upon owner transfer or relocation.

Manufacturer Warranty

All Cal Flame models are manufactured with the highest quality appliances and are warranted to be free from defects in material and workmanship at time of delivery. The appliance warranty is extended through the manufacturer of the product.

Warranty Performance

In the event of a malfunction or defect covered under the terms of this warranty, a factory authorized service agent of LMS will perform the necessary repairs. To obtain service, contact the selling dealer. In the event the consumer is unable to obtain satisfactory customer service from the selling dealer or service agent, written notification must be given to the LMS Customer Relations Department within 30 days of the reported failure. There will be no charge for parts or labor on a covered item. However, the service agent may assess a reasonable travel or mileage charge per service call. If LMS determines that repair of a covered item is not feasible, L.M.S. reserves the right to replace the defective merchandise with merchandise equal in value to the original purchase price. Warranty repair and / or replacement is the sole discretion of LMS and this warranty does not cover costs therein, including but not limited to: freight, removal, re-installation, etc. This warrant is non-transferable and may not be extended beyond the above mentioned time frames under any circumstances, by any of LMS's representatives.

Warranty Limitations

This warranty is void if the side burner has been subject to negligence, alteration, misuse, repairs, dings, dents, scratches, or incorrect and / or prohibited applications, as specified in the owner's manual. Gas lines must be installed by a licensed plumber only or local gas company agent. Incorrect electrical installation by unlicensed electricians, service by non-LMS authorized representatives, acts of God and other cases beyond the control of LMS are not covered by this warranty. Please refer to the owner's manual for examples of exclusions and common acts invalidating this warranty. This limited warranty applies only to side burners used for personal, family, and outdoor household purposes. This warranty does not apply to labor charges on side burners, replacement parts and hardware. This limitation is retroactive and applies to all side burners manufactured from 2000 and hereafter.

Legal Remedies

This limited warranty gives you specific legal rights. You may have other rights, which may vary from state to state.

Customer Service

For customer service, contact the authorized selling dealer immediately. If you need additional information or assistance, please contact the LMS Customer Relations Department at 1462 E. Ninth St., Pomona CA 91766 or call (800) 225-7727.

See your Cal Flame barbecue dealer for a copy of the applicable warranty, details and any questions you may have regarding the warranty coverage on your barbecue.

Warranty Limitations

The Limited Warranty is void if the side burner has been subject to negligence, alteration, misuse, abuse, repairs by non-LMS authorized representatives, incorrect electrical installation, acts of God and any other cases beyond the control of LMS. Examples of common acts invalidating this warranty include but are not limited to:

- Scratches caused by normal use.
- Damage caused by extreme weather conditions (hot, cold, etc.)
- Damage caused by dirt, sand, and/or water damage.

- Damage caused by continued operation of the barbecue with either known or unknown problems.
- Damage caused by direct sunlight.
- Damage caused as a result of failure to follow the operating instructions as defined in this owner's manual.

This Limited Warranty applies only to barbecues normally used for personal, family, or household purposes.

This Limited Warranty specifically excludes commercial side burners.

Warranty Exclusions

LMS warrants the side burner from defects in material and workmanship for a period of one year from the original date of purchase.

Cal Flame[®]

CONTACT INFORMATION

For customer service, please contact your authorized dealer immediately. If you need additional information and/or

assistance, please contact:
Customer Service Department

1462 East Ninth Street
Pomona, CA 91766

Toll Free: 1-800-CAL-SPAS

Fax: 1-909-629-3890

www.calspas.com